



TeraFlex JK Premium HD Drag Link Kit

www.teraflex.com

Kit:

- 1853920
- 1853930

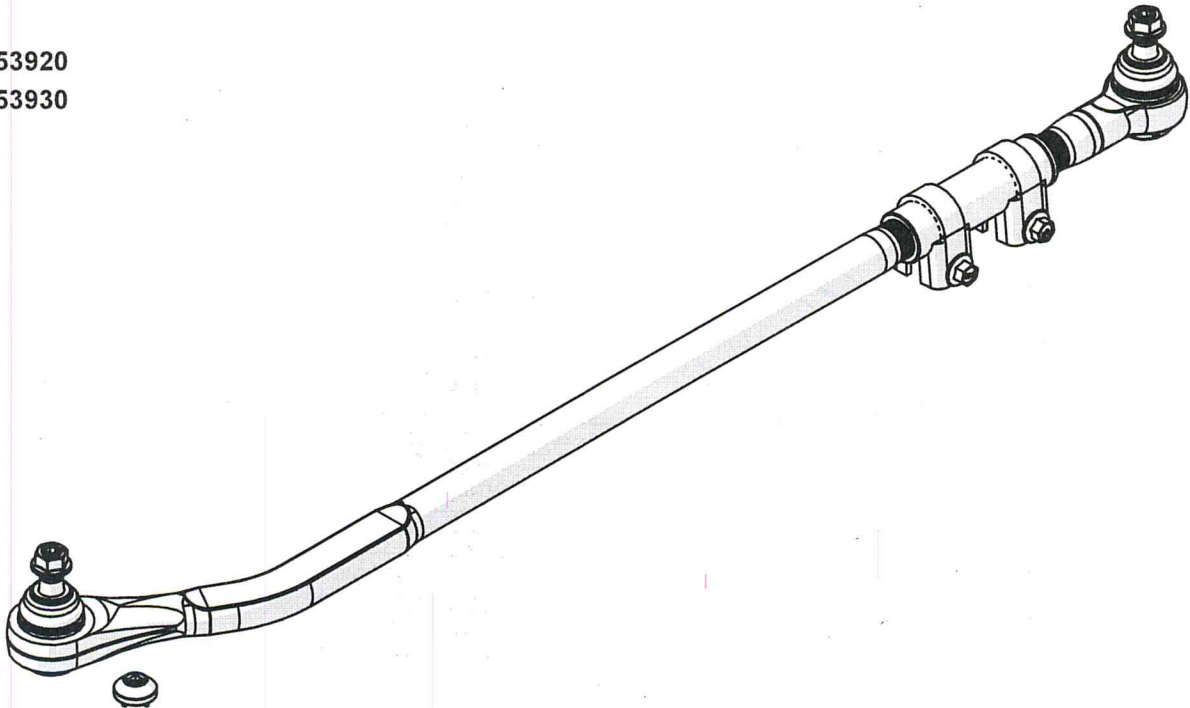

Important Notes:

Prior to beginning this or any installation read these instructions to familiarize yourself with the required steps and evaluate if you are experienced and capable to personally perform these modifications. A factory service manual should be used in conjunction with these installation instructions.

Refer to the parts list to ensure that all necessary components and hardware has been included. If any parts are missing please contact your local TeraFlex dealer for assistance.

Tools needed:

- This installation guide
- Jack
- Jack Stands
- Basic mechanics tool set
- 2.5mm Allen Wrench
- Hammer
- Blue LoCTite
- Tape Measure

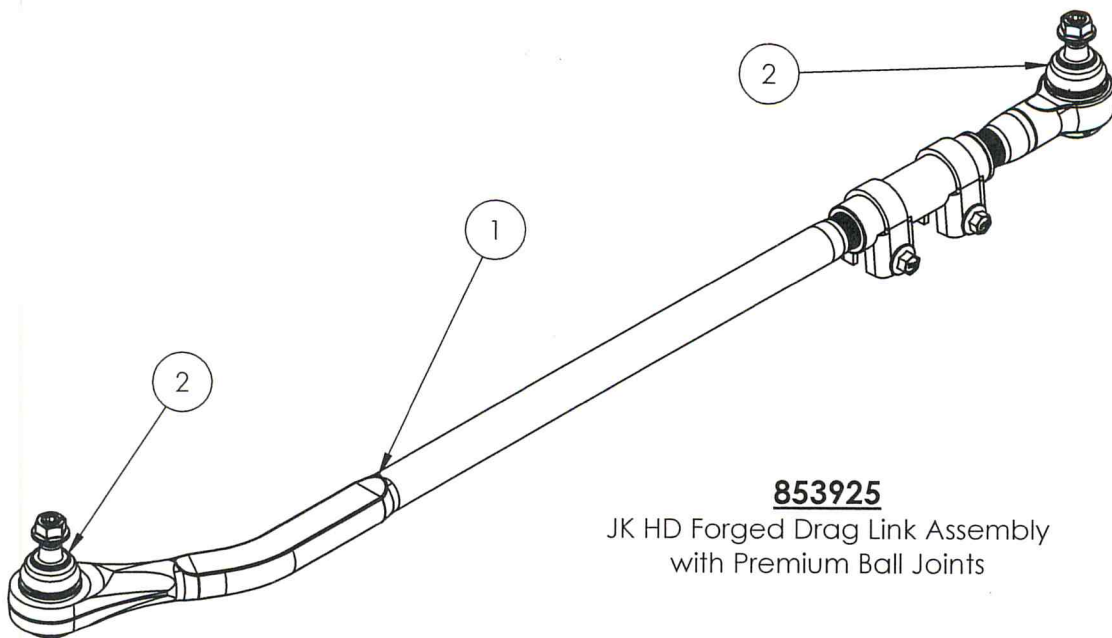

853925
JK HD Forged Drag Link Assembly
with Premium Ball Joints

ITEM NO.	PART NUMBER	DESCRIPTION	QTY.
1	853920	JK HD Forged Drag Link Assembly	1
2	344410	Premium JK Steering Ball Joint	2

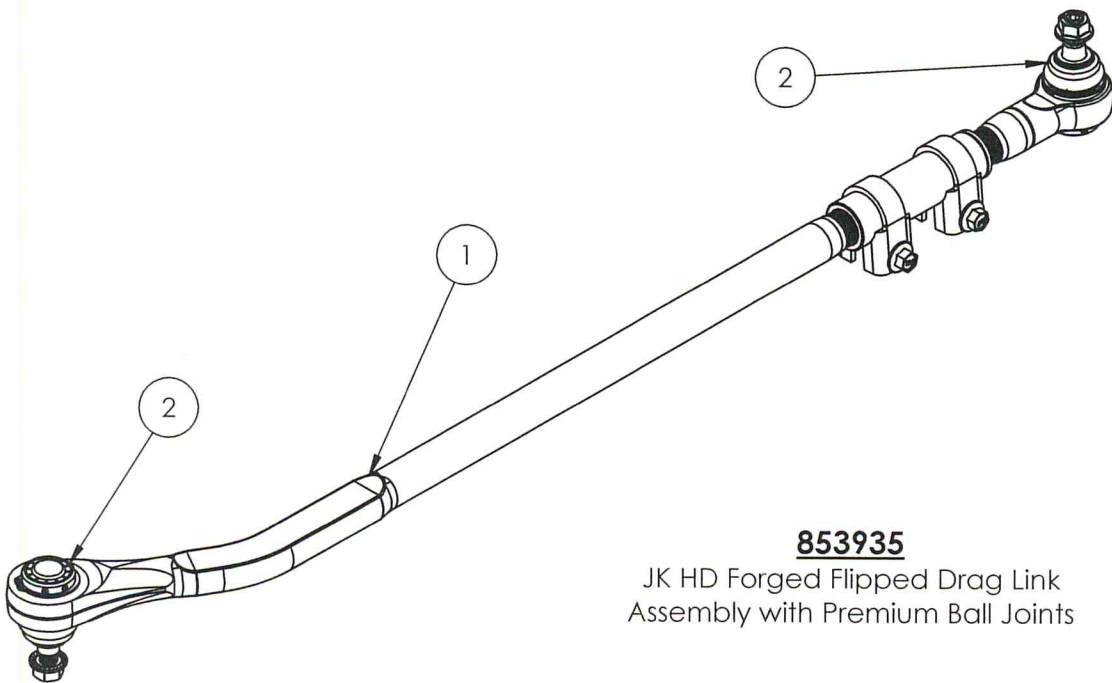

853935
JK HD Forged Flipped Drag Link
Assembly with Premium Ball Joints

ITEM NO.	PART NUMBER	DESCRIPTION	QTY.
1	853920	JK HD Forged Drag Link Assembly	1
2	344410	Premium JK Steering Ball Joint	2

ITEM NO.	PART NUMBER	DESCRIPTION	QTY.
1	212	M14X1.5 Flanged Serrated Distorted Thread Locknut for HD Steering Ball Joints	1
2	304	Set Screw M5 x 0.8 Pitch x 4mm Flat Point for HD Adjustable Ball Joints	2
3	306	Set Screw M5 x 0.8 Pitch Extended Point for HD Adjustable Ball Joints	2
4	308	Grease Zerk 1/4"-28 UNF Straight	1
5	344207	Tool Steel Washer for HD Series Ball Joints	1
6	344208	O-Ring 32mm I.D. 1.5mm Thick for HD Series Ball Joints	1
7	344401	JK HD Steering Ball Joint Rolled Pin Alignment Key	1
8	344402	JK HD Steering Ball Joint Housing	1
9	344403	JK HD Steering Ball Joint End Plate	1
10	344404	JK HD Steering Ball Joint Stud	1
11	344405	Premium JK Steering Ball Joint Bi-Fold Dust Boot	1
12	344406	Premium JK Steering Ball Joint Dust Boot Retaining Ring	1
13	344407	Premium Series Steering and Lower Ball Joint Dust Boot Retaining Spring	1
14	344408	JK HD Steering Ball Joint Grease Zerk Rubber Plug	1
15	845	Snap Ring 1.625" External for HD Series Steering and Axle Ball Joints	1

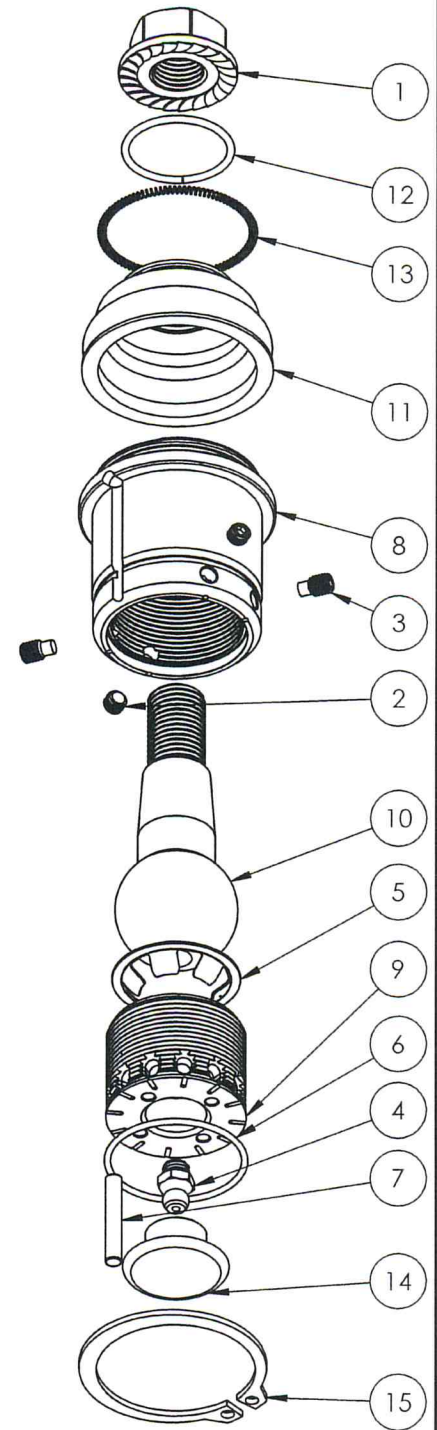

344410
Premium JK Steering Ball Joint

Reinstall your tire and wheel assembly. With your tires pointed straight, adjust your steering wheel by simply rotating the adjusting collar on your new drag link until the wheel is centered. It is important to make sure that while tightening the pinch bolts, after you have your steering wheel centered, the drag link ends on both sides are in a neutral position and are not bound up (rotated opposite directions).

(NOTE: The drag link assembly should be able to rotate up and down a few degrees. This is normal and allows for a degree change in the knuckles when turning, without steering binding.)

Finish your installation by greasing the premium joints of your new TeraFlex Drag Link with a quality grease and install #344408 Grease Zerk Dust Cover.

Enjoy your new TeraFlex HD Drag Link!

7

8

PRODUCT INFORMATION

MAINTENANCE INFORMATION:

It is the buyer's responsibility to have all suspension, drivetrain, steering, and other components checked for proper tightness and torque after the first 100 miles and every 3000 miles after that.

NOTICE TO INSTALLER:

The enclosed "Warning to Driver" sticker must be installed in the vehicle in driver's view. This sticker is to act as a constant safety reminder when operating the vehicle. It is your responsibility as the equipment installer to install the provided sticker and to forward the product instructions to the vehicle's owner for review. If a "Warning to Driver" sticker or product installation guide were not included in the kit, FREE replacement stickers and instructions are available by request. It is the installer's duty to ensure a safe and controllable vehicle after the modifications have been performed.

WARNING:

Neither the seller nor the manufacturer will be liable for any loss, damage, or injury directly or indirectly arising from the use of or inability to determine the use of these products. Before using, the user shall determine the suitability of the products for its intended use, and the user shall assume all responsibility and risk in connection therewith.

WARNING TO DRIVER:

This vehicle has been modified to enhance off road performance and has unique handling characteristics. Use in harsh environments can cause extreme stress on the components. Vehicle should be inspected after being off road to make sure that all the components are in working order and safe to travel on the highway. All fasteners should be checked so that they are at the correct torque specifications as the vibration and stresses from off roading may cause critical fasteners to work loose. Extra care should be taken to inspect the critical components, steering, and brake systems. During each oil change components such as arms, tie rod ends, etc should be greased and checked for excessive wear. Any worn components should be replaced. When returning to the pavement always set or restore tire air pressure to the factory recommendation and connect or engage any disabled sway bar mechanisms. Because of the higher center of gravity and larger tires, this vehicle handles and reacts differently than many passenger cars, both on and off road. You must drive it safely! Extreme care should be taken to prevent vehicle rollover or loss of control, which can result in serious injury or death. Avoid sudden sharp turns or abrupt maneuvers. Generally, braking performance and capabilities are decreased when significantly larger/heavier tires are used, especially when used in combination with transfer case low-range reduction kits. Take this into consideration while driving. Do not add, alter or fabricate any factory or aftermarket parts to increase vehicle height over the intended height of the TeraFlex product purchased. Mixing component brand is not recommended. TeraFlex Inc. will not be responsible for any altered product or any improper installation or use of our products. We will be happy to answer any questions concerning the design, function, and correct use of our products. It is ultimately the buyer's responsibility to have all bolts/nuts checked for tightness after the first 100 miles and then every 3000 miles. Wheel alignment, steering system, suspension and drive line systems must be inspected by a qualified professional mechanic at least every 3000 miles.

TERAFLEX PRODUCT WARRANTY:

TeraFlex Inc. warrants TeraFlex Suspension products to the original retail purchaser to be free of defects in material and workmanship for as long as the original purchaser owns the vehicle on which products were originally installed.

Failure to complete regular maintenance (grease every 3000 miles) on TeraFlex FlexArms will void this warranty. All other conditions of the standard TeraFlex product warranty apply.

All TeraLow products are covered by the TeraFlex two (2) year warranty to be free of defects in material and workmanship for two years from date purchased.

TeraFlex axles are covered by a 12-month warranty to be free of defects in materials and workmanship.

This warranty does not cover or include product finish, improperly installed or applied products, improperly maintained products, products or components used for racing or competition or damage due to abuse or neglect, products that fail due to the use of larger tire and wheel combinations.

All returns must be accompanied by an original invoice. It is the customer's responsibility to remove the product from the vehicle. Shipping charges are the responsibility of the customer. TeraFlex Inc. will pay the return freight if the product meets the terms of warranty.

This warranty is for the replacement or repair of defective TeraFlex products only and does not include freight charges, labor charges for removal of or installation of TeraFlex or related products or components, costs incurred due to down time of the vehicle, or lost profits due to vehicle down time.

A returned goods authorization number (RGA#) must accompany any returned products. For more information please contact a TeraFlex customer service representative.

COPYRIGHT

©Copyright 2014. All rights reserved, TeraFlex Inc. Reproduction of this catalog and/or any of its contents without written permission is strictly prohibited.

TeraFlex® is a registered trademark of TeraFlex Inc. All trade names and logos including but not limited to TeraFlex, FlexArms, RockGuard, Monster, and LCG are protected by law and duplication of trade names and/or logos are strictly prohibited.

TeraFlex Inc. reserves the right to update, discontinue, redesign, modify finish, part number or component build parts if deemed necessary without written notice. TeraFlex Inc., and any associated dealers are not responsible for misprints or typographical errors that may have inadvertently been made within this instruction sheet.

Jeep® and the Jeep® grill are registered trademarks of Fiat Chrysler Automobiles N.V., and have no affiliation with TeraFlex Inc.